



8 pt. 24VDC High Speed Input Module

Delivery Code
STK

Module Specifications	
Number of Inputs	8 (sink/source)
Input Voltage Range	10-28 VDC
Peak Voltage	40 VDC
Input Current	1.92 mA @ 12 VDC 4.0 mA @ 24 VDC
Maximum Input Current	5 mA @ 28 VDC
Input Impedance	5.6k @ 10-28 VDC
ON Voltage Level	> 10 VDC
OFF Voltage Level	< 2 VDC
Min. ON Current	1.5 mA
Min. OFF Current	0.2 mA
OFF to ON Response	0.2-0.4 ms, typical 0.3 ms
ON to OFF Response	0.2-0.4 ms, typical 0.3 ms
Status Indicators	Red LED for each output
Commons	2 points
Fuse	No Fuse
Base Power Required (3.3V)	Typical 15 mA (all inputs on)
Optical Isolation	2500 Volt
Wires	1 of 14 AWG, 2 of 18 AWG, 4 of 22 AWG

EZIO-8HSDCI Snap-in



Terminal Block 300 Volt/10 Amp/ 14AWG UL Rating



EZIO-8HSDCI Screw-down

Pinout Information	
Pin No.	EZIO-8HSDCI
1	Input(1)
2	Input(2)
3	Input(3)
4	Input(4)
5	COM
6	Input(5)
7	Input(6)
8	Input(7)
9	Input(8)
10	COM
11	Not Connected

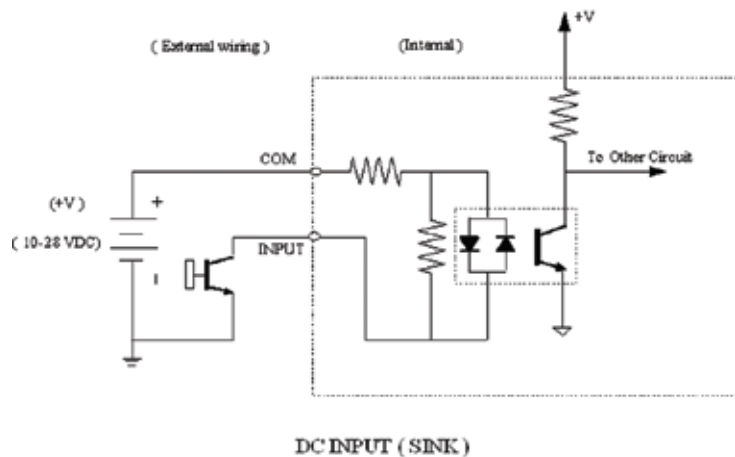
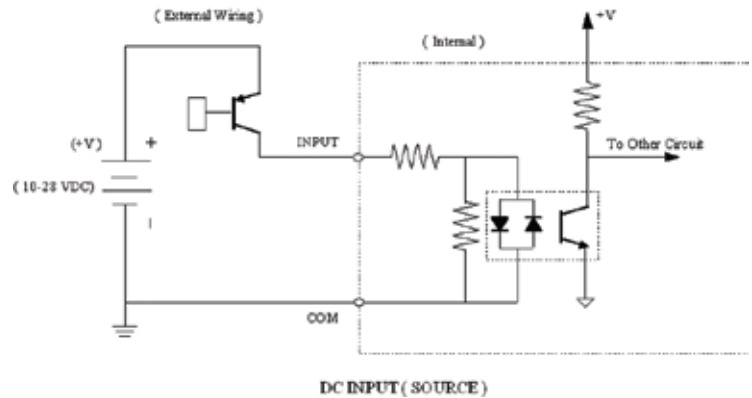

For EZ-LINK cables and Terminal boards look at page 9-4